

JUMO GmbH & Co. KG
Delivery address: Mackenrodtstraße 14
36039 Fulda, Germany
Postal address: 36035 Fulda, Germany
Phone: +49 661 6003-0
Fax: +49 661 6003-607
Email: mail@jumo.net
Internet: www.jumo.net

JUMO Instrument Co. Ltd.
JUMO House
Temple Bank, Riverway
Harlow, Essex, CM20 2DY, UK
Phone: +44 1279 63 55 33
Fax: +44 1279 62 50 29
Email: sales@jumo.co.uk
Internet: www.jumo.co.uk

JUMO Process Control, Inc.
6733 Myers Road
East Syracuse, NY 13057, USA
Phone: +1 315 437 5866
Fax: +1 315 437 5860
Email: info.us@jumo.net
Internet: www.jumousa.com



JUMO MIDAS C08

OEM Pressure Transmitter – Basic

Applications

- compressors
- machinery and plant engineering
- industrial pneumatics
- commercial vehicles
- building technology

Brief description

This pressure transmitter is used as the core product for the MIDAS range for applications requiring reliable implementation of measuring tasks with long-term stability and excellent price-performance ratio. The MIDAS range provides solutions for all applications on the basis of this core product.

The innovative and patented sensor design of the specifically developed ceramic sensor provides excellent long-term stability of < 0.2 %. It can be used for recording relative pressures of 1.6 bar to 60 bar in gaseous or liquid media.



Type 401002 with QUICKON



Type 401002 with M12 × 1 connector

Customer benefits

- **process-reliable**
Through constructive measures, the pressure transmitter achieves excellent vibration resistance and enables application under high vibration load, as occurs in commercial vehicles for example. The throughput through the fully automatic measuring and calibration devices, the diagnostic function of the switching circuit, and the full final inspection complete the high standard of quality.
- **economic**
The QUICKON quick-clamp technology enables quicker and safer installation. The connection is even guaranteed with any temperature fluctuations that may occur thanks to the spring contacts. This electrical connection means that installation times can be shortened and as a result, costs are reduced by 60 % compared to conventional connection options.
- **versatile**
The universal application is reflected by the wide choice of measuring ranges, process connections, and electrical connections.

Special features

- long-term stability < 0.2 %
- new level of quality for the OEM sector
- 60 % quicker device installation with the QUICKON quick-clamp technology
- temperature compensation range increased by 50 % to -20 °C to +100 °C
- 2.5 times more vibration resistance than the industry standard
- made in Germany

Approvals and approval marks (see "Technical data")



JUMO GmbH & Co. KG
 Delivery address: Mackenrodtstraße 14
 36039 Fulda, Germany
 Postal address: 36035 Fulda, Germany
 Phone: +49 661 6003-0
 Fax: +49 661 6003-607
 Email: mail@jumo.net
 Internet: www.jumo.net

JUMO Instrument Co. Ltd.
 JUMO House
 Temple Bank, Riverway
 Harlow, Essex, CM20 2DY, UK
 Phone: +44 1279 63 55 33
 Fax: +44 1279 62 50 29
 Email: sales@jumo.co.uk
 Internet: www.jumo.co.uk

JUMO Process Control, Inc.
 6733 Myers Road
 East Syracuse, NY 13057, USA
 Phone: +1 315 437 5866
 Fax: +1 315 437 5860
 Email: info.us@jumo.net
 Internet: www.jumousa.com



Technical data

General Information

Reference conditions	DIN 16086 and DIN EN 60770
Sensor	
Measuring principle	Thick film on ceramic bodies (piezo-resistive)
Admissible load changes	> 10 million, 0 to 100 % measuring range
Mounting position	Any
Calibration position	Device upright, process connection at the bottom

Measuring range and accuracy

Measuring range	Linearity ^a % MSP ^f	Accuracy at			Long-term stability ^b % MSP per year	Overload capacity ^c bar	Burst pressure bar
		20 °C ^d % MSP	-10 to +85 °C ^e % MSP	-20 to +100 °C ^e % MSP			
0 to 1.6 bar relative pressure	0.25	0.5	0.65	1	0.2	6	12
0 to 2.5 bar relative pressure						6	12
0 to 4 bar relative pressure		0.35	0.5			12	25
0 to 6 bar relative pressure						12	25
0 to 10 bar relative pressure		0.5	0.65			20	38
0 to 16 bar relative pressure						50	75
0 to 25 bar relative pressure		0.35	0.5			50	75
0 to 40 bar relative pressure						120	200
0 to 60 bar relative pressure		0.5	0.65			120	200
-1 to +0.6 bar relative pressure						6	12
-1 to +1.5 bar relative pressure		0.35	0.5			6	12
-1 to +3 bar relative pressure						12	25
-1 to +5 bar relative pressure		0.5	0.65			12	25
-1 to +9 bar relative pressure						20	38
-1 to +15 bar relative pressure		0.35	0.5			50	75
-1 to +24 bar relative pressure						50	75

^a Linearity according to limit point setting

^b Reference conditions EN 61298-1

^c All pressure transmitters are vacuum-proof.

^d Includes: linearity, hysteresis, repeatability, deviation of measuring range initial value and measuring range end value

^e Includes: linearity, hysteresis, repeatability, deviation of measuring range initial value and measuring range end value, thermal effect on measuring range start and measuring span

^f MSP = Measuring span

JUMO GmbH & Co. KG
 Delivery address: Mackenrodtstraße 14
 36039 Fulda, Germany
 Postal address: 36035 Fulda, Germany
 Phone: +49 661 6003-0
 Fax: +49 661 6003-607
 Email: mail@jumo.net
 Internet: www.jumo.net

JUMO Instrument Co. Ltd.
 JUMO House
 Temple Bank, Riverway
 Harlow, Essex, CM20 2DY, UK
 Phone: +44 1279 63 55 33
 Fax: +44 1279 62 50 29
 Email: sales@jumo.co.uk
 Internet: www.jumo.co.uk

JUMO Process Control, Inc.
 6733 Myers Road
 East Syracuse, NY 13057, USA
 Phone: +1 315 437 5866
 Fax: +1 315 437 5860
 Email: info.us@jumo.net
 Internet: www.jumousa.com



Output

Analog output ^a Current Voltage	4 to 20 mA, two-wire (output 405) DC 0.5 to 4.5 V, three-wire, ratiometric 10 to 90 % of the voltage supply (output 412) DC 0 to 10 V, three-wire (output 415) DC 1 to 5 V, three-wire (output 418) DC 1 to 6 V, three-wire (output 420)
Step response T ₉₀	≤ 2 ms
Burden Current Voltage (burden connected to "0 V/S-")	R _L ≤ (U _B -8 V) ÷ 0.02 A (Ω) at 4 to 20 mA, two-wire (output 405) R _L ≥ 5 kΩ at DC 0.5 to 4.5 V, three-wire (output 412) R _L ≥ 10 kΩ at DC 0 to 10 V, three-wire (output 415) R _L ≥ 10 kΩ at DC 1 to 5 V, three-wire (output 418) R _L ≥ 10 kΩ at DC 1 to 6 V, three-wire (output 420)

^a Further outputs are available upon request.

Mechanical features

Material Process connection for push-in fitting (process connection 383) Seal 600 (internal ^a) Seal 601 (internal ^a) Seal 602 (internal ^a) Seal 604 (internal ^a) Seal 609 (internal ^a) for G 1/4 (process connection 521) (external ^a) Sensor Housing Attached cable (electrical connection 11) QUICKON (electrical connection 23) Round plug M12 × 1 (electrical connection 36) Bayonet connector (electrical connection 53) Cable socket (electrical connection 61)	Stainless steel 304 Brass, nickel-plated EPDM FKM, standard CR FFKM NBR FKM Ceramic Al ₂ O ₃ 96 % Stainless steel 304 PBT-GF30, PVC PBT-GF30 PBT-GF30, stainless steel 303 L PBT-GF30 PBT-GF30, PA, silicone
Weight	70 g with G 1/4 (process connection 502)

^a Ensure the medium durability of the seal material!

JUMO GmbH & Co. KG
 Delivery address: Mackenrodtstraße 14
 36039 Fulda, Germany
 Postal address: 36035 Fulda, Germany
 Phone: +49 661 6003-0
 Fax: +49 661 6003-607
 Email: mail@jumo.net
 Internet: www.jumo.net

JUMO Instrument Co. Ltd.
 JUMO House
 Temple Bank, Riverway
 Harlow, Essex, CM20 2DY, UK
 Phone: +44 1279 63 55 33
 Fax: +44 1279 62 50 29
 Email: sales@jumo.co.uk
 Internet: www.jumo.co.uk

JUMO Process Control, Inc.
 6733 Myers Road
 East Syracuse, NY 13057, USA
 Phone: +1 315 437 5866
 Fax: +1 315 437 5860
 Email: info.us@jumo.net
 Internet: www.jumousa.com



Environmental influences

Medium temperature for electrical connection Attached cable Round plug M12 × 1 Bayonet connector Cable socket	-20 to +125 °C -20 to +125 °C -20 to +125 °C -20 to +125 °C
Ambient temperature for electrical connection Attached cable Round plug M12 × 1 Bayonet connector Cable socket	-20 to +100 °C At ambient temperature of -30 °C restricted function. Only use when stationary. Risk of cable break. -20 to +100 °C -20 to +100 °C -20 to +100 °C
Storage temperature for electrical connection Attached cable Round plug M12 × 1 Bayonet connector Cable socket	-30 to +100 °C -40 to +100 °C -40 to +100 °C -40 to +100 °C
Admissible humidity Operation Storage	100 % rel. humidity including condensation on the device outer case 90 % rel. humidity without condensation
Admissible mechanical load Vibration resistance Shock resistance	50 g for 10 to 2000 Hz, according to IEC 60068-2-6 50 g for 3 ms, 100 g for 2 ms, according to IEC 60068-2-27
Electromagnetic compatibility Interference emission Interference immunity	according to EN 61326-2-3 Class B ^a Industrial requirement
Protection type for electrical connection Attached cable QUICKON ^b Round plug M12 × 1 ^c Bayonet connector ^c Cable socket ^{c, d}	according to EN 60529 IP67 IP67 IP67 IP67 IP65

^a The product is suitable for industrial use as well as for households and small businesses.

^b Connecting cable diameter, minimum 3.5 mm, maximum 6 mm

^c The protection type is only achieved with a suitable mounted counter piece.

^d Connecting cable diameter, minimum 6 mm, maximum 8 mm

JUMO GmbH & Co. KG
 Delivery address: Mackenrodtstraße 14
 36039 Fulda, Germany
 Postal address: 36035 Fulda, Germany
 Phone: +49 661 6003-0
 Fax: +49 661 6003-607
 Email: mail@jumo.net
 Internet: www.jumo.net

JUMO Instrument Co. Ltd.
 JUMO House
 Temple Bank, Riverway
 Harlow, Essex, CM20 2DY, UK
 Phone: +44 1279 63 55 33
 Fax: +44 1279 62 50 29
 Email: sales@jumo.co.uk
 Internet: www.jumo.co.uk

JUMO Process Control, Inc.
 6733 Myers Road
 East Syracuse, NY 13057, USA
 Phone: +1 315 437 5866
 Fax: +1 315 437 5860
 Email: info.us@jumo.net
 Internet: www.jumousa.com



Auxiliary power

Voltage supply U_B^a 4 to 20 mA, two-wire (output 405) DC 0.5 to 4.5 V, three-wire (output 412) DC 0 to 10 V, three-wire (output 415) DC 1 to 5 V, three-wire (output 418) DC 1 to 6 V, three-wire (output 420)	DC 8 to 30 V, rated voltage supply DC 24 V DC 3 to 5.25 V, rated voltage supply DC 5 V, ratiometric output 10 to 90 % of the voltage supply DC 11.5 to 30 V, rated voltage supply DC 24 V DC 8 to 30 V, rated voltage supply DC 24 V DC 8 to 30 V, rated voltage supply DC 24 V
Current consumption incl. load 4 to 20 mA, two-wire (output 405) DC 0.5 to 4.5 V, three-wire (output 412) DC 0 to 10 V, three-wire (output 415) DC 1 to 5 V, three-wire (output 418) DC 1 to 6 V, three-wire (output 420)	≤ 25 mA ≤ 3 mA ≤ 3 mA ≤ 3 mA ≤ 3 mA
Reverse voltage protection	Yes
Electrical circuit Requirements	SELV The device must be equipped with an electrical circuit that meets the requirements of EN 61010-1 with regard to "Limited-energy circuits".

^a Residual ripple: the voltage peaks must not exceed or fall below the specified voltage supply values!

Approvals and approval marks

Approval mark	Testing agency	Certificate/certification number	Inspection basis	Valid for
c UL us	Underwriters Laboratories	E201387	UL 61010-1 (3. Ed.), CAN/CSA-22.2 No. 61010-1 (3. Ed.)	Only in connection with extra code 061; observe order details

JUMO GmbH & Co. KG
 Delivery address: Mackenrodtstraße 14
 36039 Fulda, Germany
 Postal address: 36035 Fulda, Germany
 Phone: +49 661 6003-0
 Fax: +49 661 6003-607
 Email: mail@jumo.net
 Internet: www.jumo.net

JUMO Instrument Co. Ltd.
 JUMO House
 Temple Bank, Riverway
 Harlow, Essex, CM20 2DY, UK
 Phone: +44 1279 63 55 33
 Fax: +44 1279 62 50 29
 Email: sales@jumo.co.uk
 Internet: www.jumo.co.uk

JUMO Process Control, Inc.
 6733 Myers Road
 East Syracuse, NY 13057, USA
 Phone: +1 315 437 5866
 Fax: +1 315 437 5860
 Email: info.us@jumo.net
 Internet: www.jumousa.com



Dimensions

Electrical connection

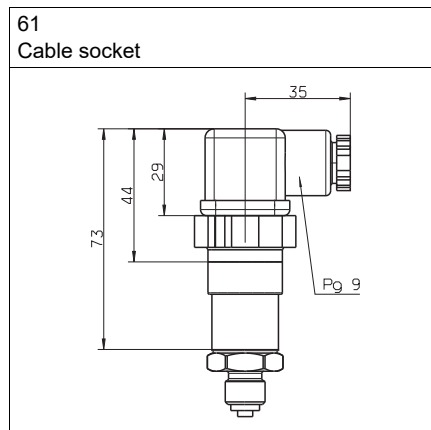
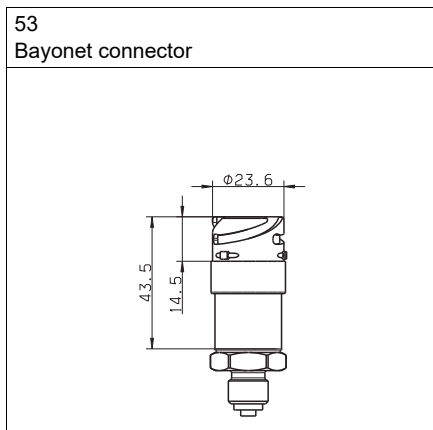
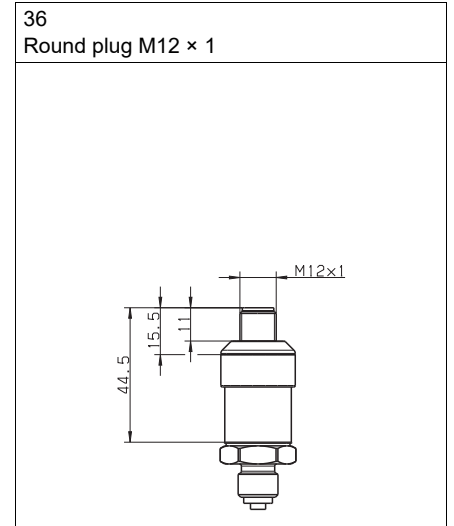
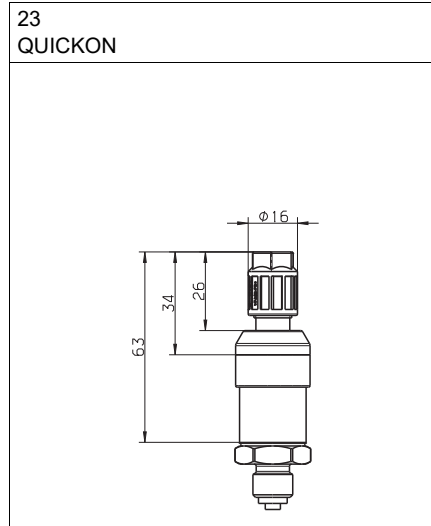
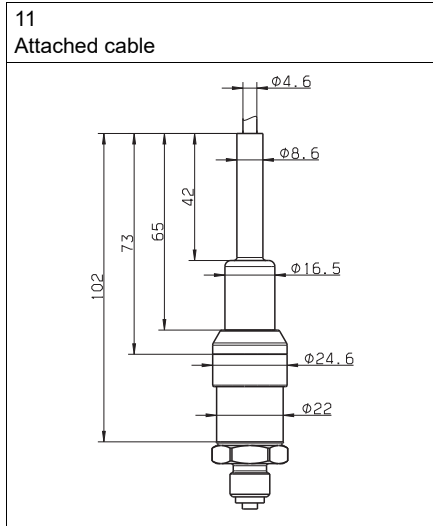

JUMO GmbH & Co. KG
 Delivery address: Mackenrodtstraße 14
 36039 Fulda, Germany
 Postal address: 36035 Fulda, Germany
 Phone: +49 661 6003-0
 Fax: +49 661 6003-607
 Email: mail@jumo.net
 Internet: www.jumo.net

JUMO Instrument Co. Ltd.
 JUMO House
 Temple Bank, Riverway
 Harlow, Essex, CM20 2DY, UK
 Phone: +44 1279 63 55 33
 Fax: +44 1279 62 50 29
 Email: sales@jumo.co.uk
 Internet: www.jumo.co.uk

JUMO Process Control, Inc.
 6733 Myers Road
 East Syracuse, NY 13057, USA
 Phone: +1 315 437 5866
 Fax: +1 315 437 5860
 Email: info.us@jumo.net
 Internet: www.jumousa.com



Process connection

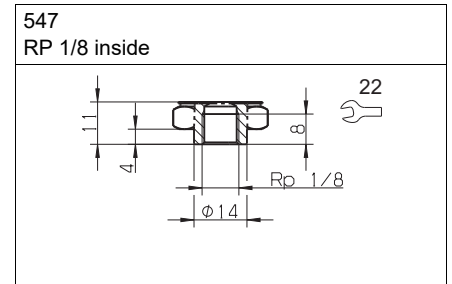
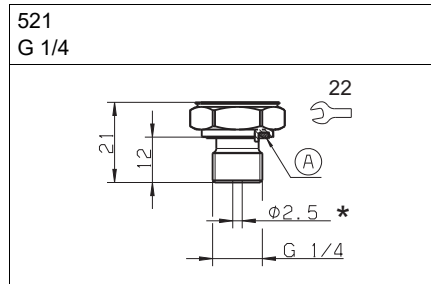
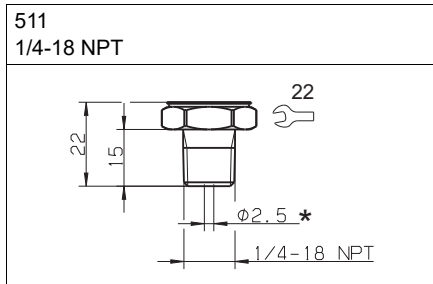
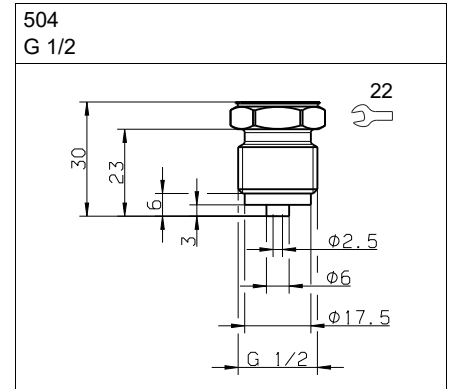
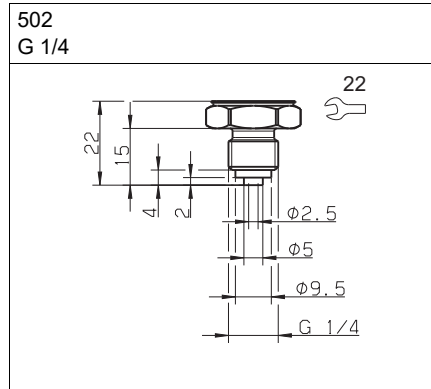
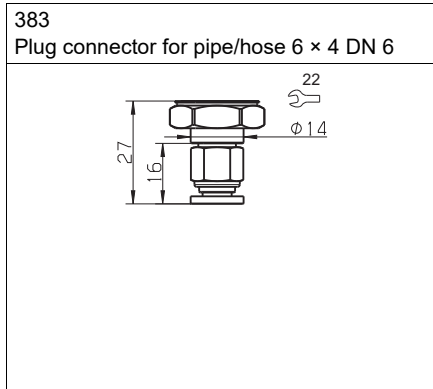

* Extra code 630 pressure channel
 Ø 8 mm

A Profile seal G 1/4
 * Extra code 630 pressure channel
 Ø 8 mm

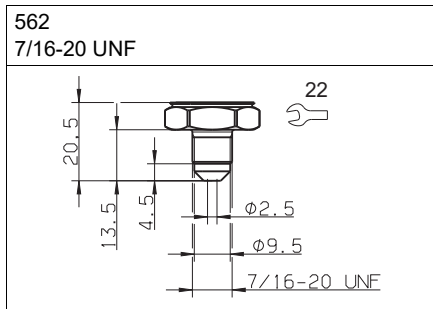

JUMO GmbH & Co. KG
 Delivery address: Mackenrodtstraße 14
 36039 Fulda, Germany
 Postal address: 36035 Fulda, Germany
 Phone: +49 661 6003-0
 Fax: +49 661 6003-607
 Email: mail@jumo.net
 Internet: www.jumo.net



JUMO Instrument Co. Ltd.
 JUMO House
 Temple Bank, Riverway
 Harlow, Essex, CM20 2DY, UK
 Phone: +44 1279 63 55 33
 Fax: +44 1279 62 50 29
 Email: sales@jumo.co.uk
 Internet: www.jumo.co.uk

JUMO Process Control, Inc.
 6733 Myers Road
 East Syracuse, NY 13057, USA
 Phone: +1 315 437 5866
 Fax: +1 315 437 5860
 Email: info.us@jumo.net
 Internet: www.jumousa.com

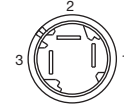
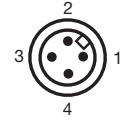
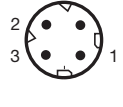
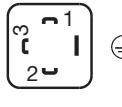

Connection diagram

The connection diagram in the data sheet provides preliminary information about the connection options. For the electrical connection, only use the installation instructions or the operating manual. The knowledge and the correct technical compliance with the safety information and warnings contained in these documents are mandatory for mounting, electrical connection, and startup as well as for safety during operation.

Connection		Terminal assignment (figure: connection to the pressure transmitter)				
						
		Attached cable	QUICKON	Round plug M12 × 1	Bayonet connector	Cable socket
4 to 20 mA, two-wire (output 405)						
Voltage supply DC 8 to 30 V	U _B /S+	WH	1	1	1	1
	0 V/S-	BN	3	3	2	2
DC 0.5 to 4.5 V ratiometric (output 412)						
Voltage supply DC 3 to 5.25 V	U _B	WH	1	1	1	1
Ratiometric output 10 to 90 % of the voltage supply	0 V/S-	BN	2	2	2	2
	S+	GN	3	3	3	3
DC 0 to 10 V, three-wire (output 415)						
Voltage supply DC 11.5 to 30 V	U _B	WH	1	1	1	1
	0 V/S-	BN	2	2	2	2
	S+	GN	3	3	3	3
DC 1 to 5 V, three-wire (output 418) DC 1 to 6 V, three-wire (output 420)						
Voltage supply DC 8 to 30 V	U _B	WH	1	1	1	1
	0 V/S-	BN	2	2	2	2
	S+	GN	3	3	3	3
Functional bonding conductor FB ^a		-	-	4	-	-

^a The pressure transmitter has to be connected to the potential equalization system of the plant through the electrical connection or process connection.

Color coding: connecting cable round plug M12 × 1	1 BN	Brown
	2 WH	White
	3 BU	Blue
	4 BK	Black

The color coding is **only** valid for A-coded standard cables!

JUMO GmbH & Co. KG

Delivery address: Mackenrodtstraße 14
36039 Fulda, Germany
Postal address: 36035 Fulda, Germany
Phone: +49 661 6003-0
Fax: +49 661 6003-607
Email: mail@jumo.net
Internet: www.jumo.net

JUMO Instrument Co. Ltd.

JUMO House
Temple Bank, Riverway
Harlow, Essex, CM20 2DY, UK
Phone: +44 1279 63 55 33
Fax: +44 1279 62 50 29
Email: sales@jumo.co.uk
Internet: www.jumo.co.uk

JUMO Process Control, Inc.

6733 Myers Road
East Syracuse, NY 13057, USA
Phone: +1 315 437 5866
Fax: +1 315 437 5860
Email: info.us@jumo.net
Internet: www.jumousa.com



Order details

(1) Basic type	
401002/000	JUMO MIDAS C08 – OEM pressure transmitter – basic
401002/999	JUMO MIDAS C08 – OEM pressure transmitter – basic, special version
(2) Input	
455	0 to 1.6 bar relative pressure
456	0 to 2.5 bar relative pressure
457	0 to 4 bar relative pressure
458	0 to 6 bar relative pressure
459	0 to 10 bar relative pressure
460	0 to 16 bar relative pressure
461	0 to 25 bar relative pressure
462	0 to 40 bar relative pressure
463	0 to 60 bar relative pressure
479	-1 to +0.6 bar relative pressure
480	-1 to +1.5 bar relative pressure
481	-1 to +3 bar relative pressure
482	-1 to +5 bar relative pressure
483	-1 to +9 bar relative pressure
484	-1 to +15 bar relative pressure
485	-1 to +24 bar relative pressure
999	Special measuring range for relative pressure
(3) Output	
405	4 to 20 mA, two-wire
412	0.5 to 4.5 V, three-wire, ratiometric
415	0 to 10 V, three-wire
418	1 to 5 V, three-wire
420	1 to 6 V, three-wire
(4) Process connection	
383	Push-in fitting for pipe/hose 6 × 4 DN 6
502	G 1/4 DIN EN 837
504	G 1/2 DIN EN 837
511	1/4-18 NPT DIN EN 837
521	G 1/4 DIN
547	Rp 1/8 inside
562	7/16-20 UNF
(5) Process connection material	
20	CrNi (stainless steel)
(6) Material seal	
600	EPDM
601	FKM ^a
602	CR
604	FFKM
609	NBR
999	Special material

JUMO GmbH & Co. KG
 Delivery address: Mackenrodtstraße 14
 36039 Fulda, Germany
 Postal address: 36035 Fulda, Germany
 Phone: +49 661 6003-0
 Fax: +49 661 6003-607
 Email: mail@jumo.net
 Internet: www.jumo.net

JUMO Instrument Co. Ltd.
 JUMO House
 Temple Bank, Riverway
 Harlow, Essex, CM20 2DY, UK
 Phone: +44 1279 63 55 33
 Fax: +44 1279 62 50 29
 Email: sales@jumo.co.uk
 Internet: www.jumo.co.uk

JUMO Process Control, Inc.
 6733 Myers Road
 East Syracuse, NY 13057, USA
 Phone: +1 315 437 5866
 Fax: +1 315 437 5860
 Email: info.us@jumo.net
 Internet: www.jumousa.com



(7) Electrical connection	
11	Attached cable ^b
23	Quickon
36	Round plug M12 × 1
53	Bayonet connector DIN 72585
61	Cable socket DIN EN 175301-803, Form A
(8) Extra codes	
000	None
061	UL approval ^c
591	Choke in the pressure channel
624	Oil and grease free
630	Enlarged pressure channel ^d
876	Test report

^a Standard

^b The standard cable length is 2 m. Further lengths are available upon request.



^c The UL approval stipulates use of the pressure transmitter indoors. In addition, process connection 383 as well as seals 609 and 999 are not possible. Special measuring ranges (input) are not allowed to exceed the 60 bar limit.

^d An enlarged pressure channel of diameter Ø 8 mm is only available with process connection 1/4-18 NPT (process connection 511), G 1/4 (process connection 521) and the seal FKM (seal material 601).

Order code - - - - - - / , ...^a
Order example 401002/000 - 460 - 412 - 504 - 20 - 600 - 36 / 591

^a List extra codes in sequence, separated by commas.

Accessories

Item	Description	Part no.
Cable box, straight 	The PVC connecting cable is 2 m in length and has a 4-pin, straight M12 × 1 connector with gold-plated contacts on the device side.	00404585
Cable box, angled 	The PVC connecting cable is 2 m in length and has a 4-pin, angled M12 × 1 connector with gold-plated contacts on the device side.	00409334